

4E : The Quantum Universe



Lecture 7, April 7

Vivek Sharma

modphys@hepmail.ucsd.edu

Emission & Absorption Line Spectra of Elements

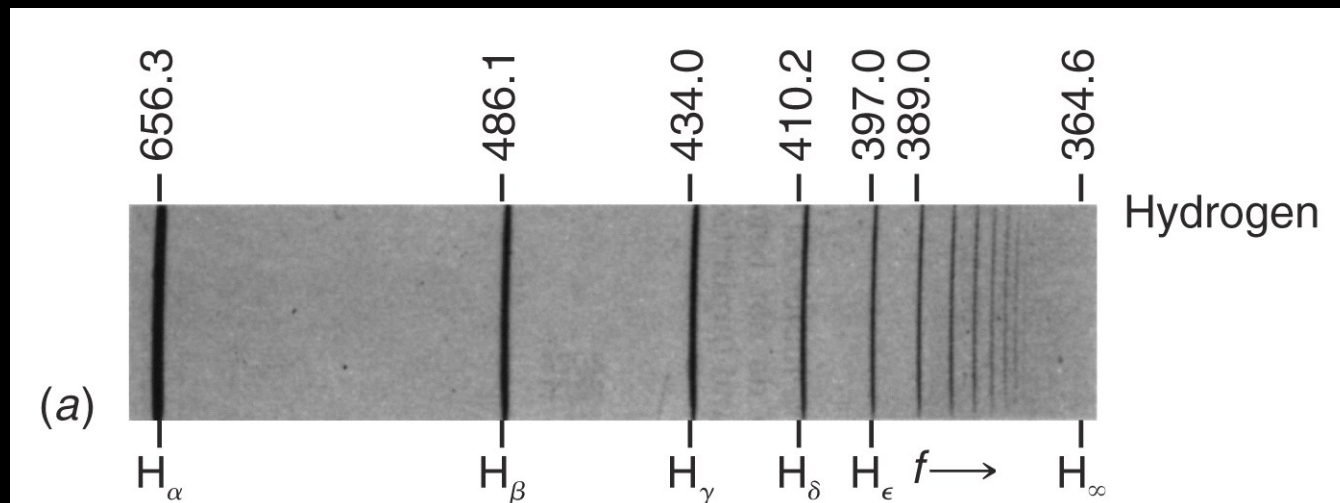
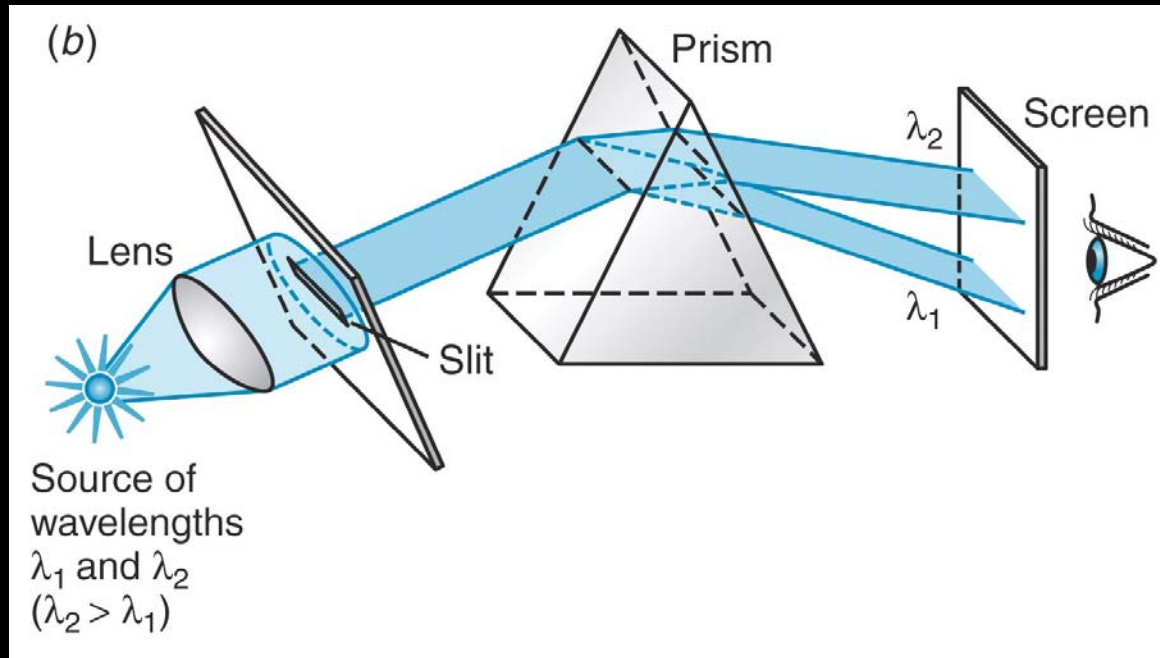

Kirchhoff's Experiment : "D" Lines in Na

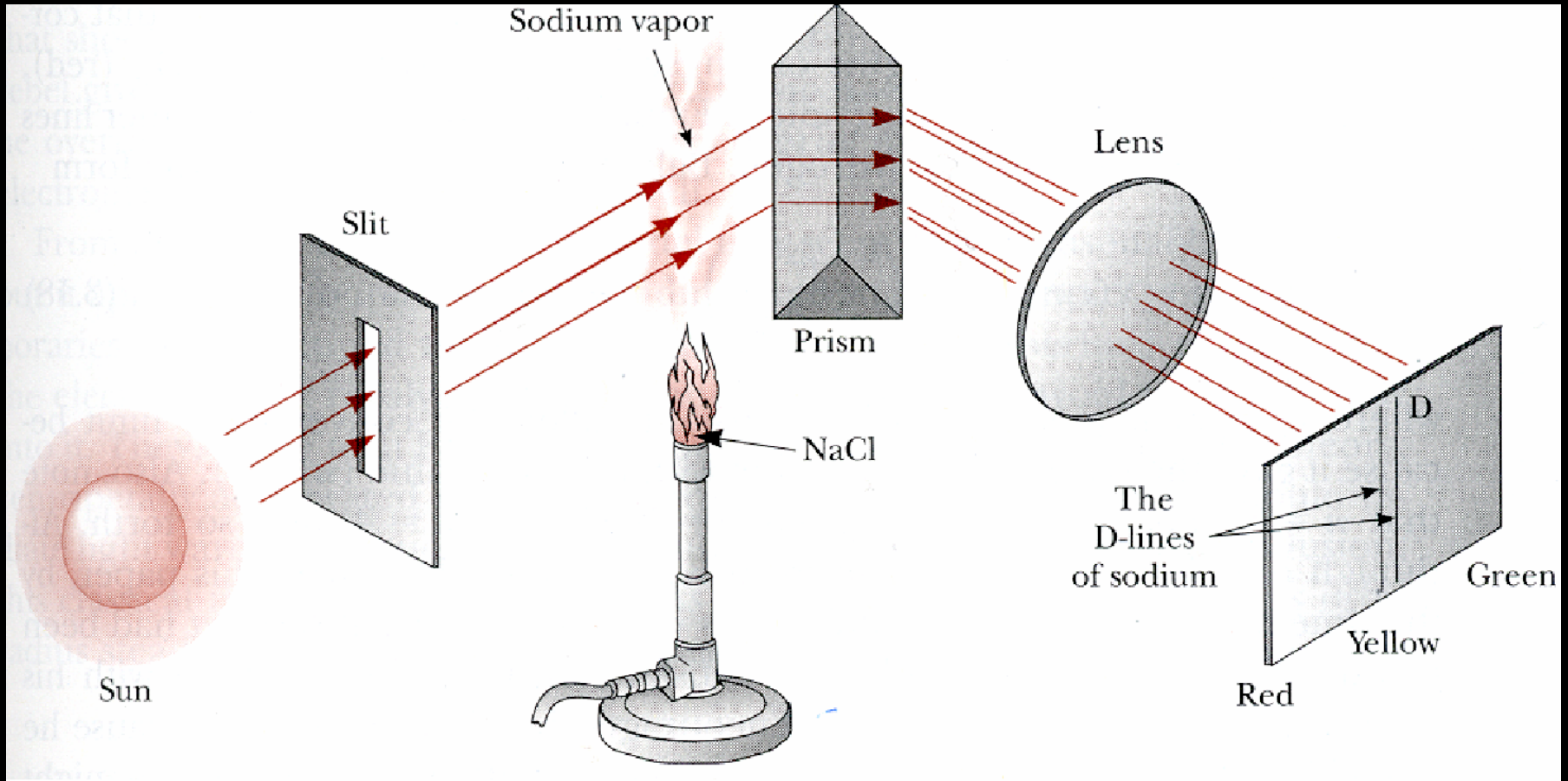

D lines darken noticeably when Sodium vapor introduced
Between slit and prism

Emission & Absorption Line Spectrum of Elements



Emission line appear dark because of photographic exposure

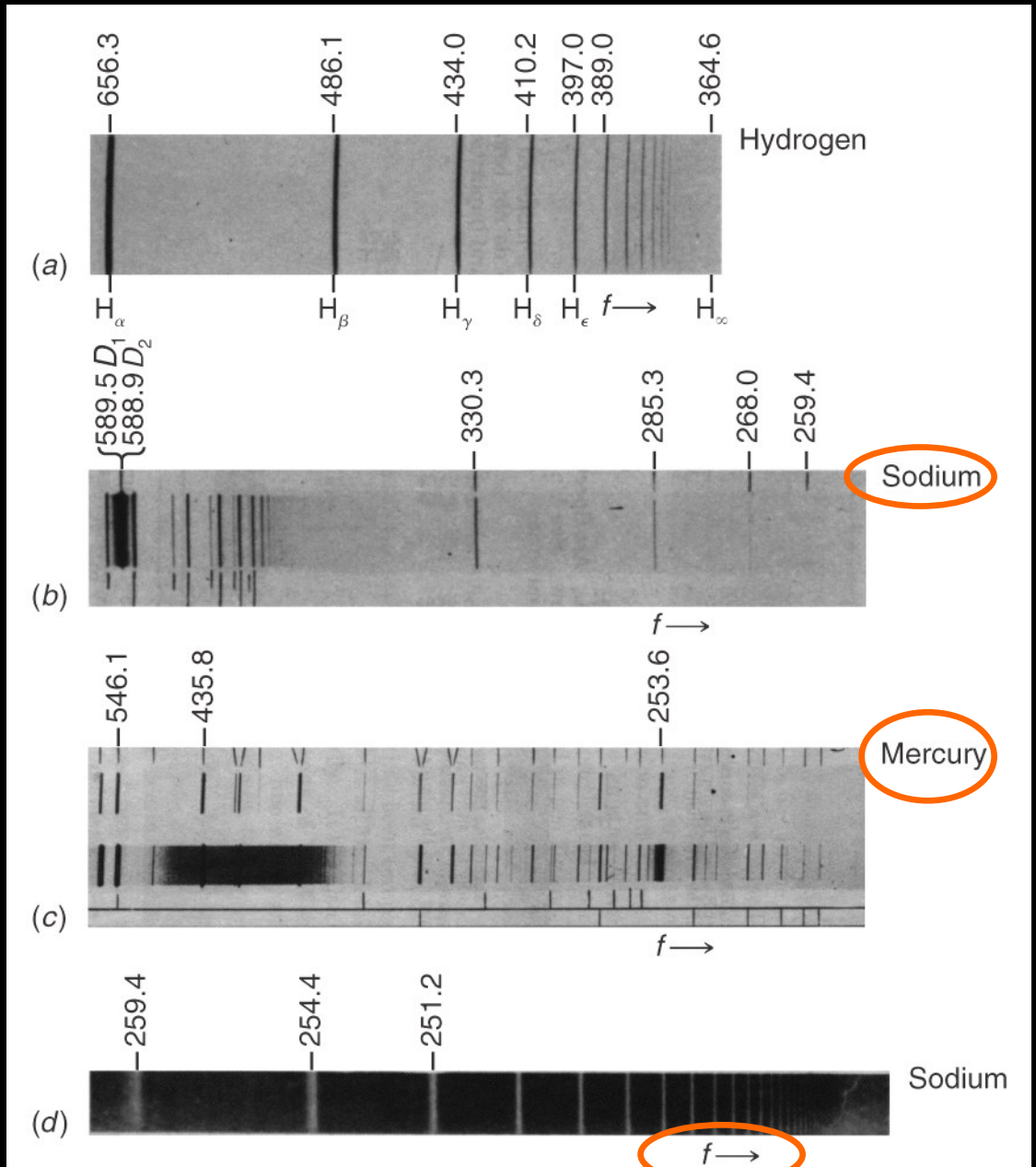

Absorption spectrum of Na

While light passed thru Na vapor is absorbed at specific λ

Spectral Observations : Series of Lines With a Pattern

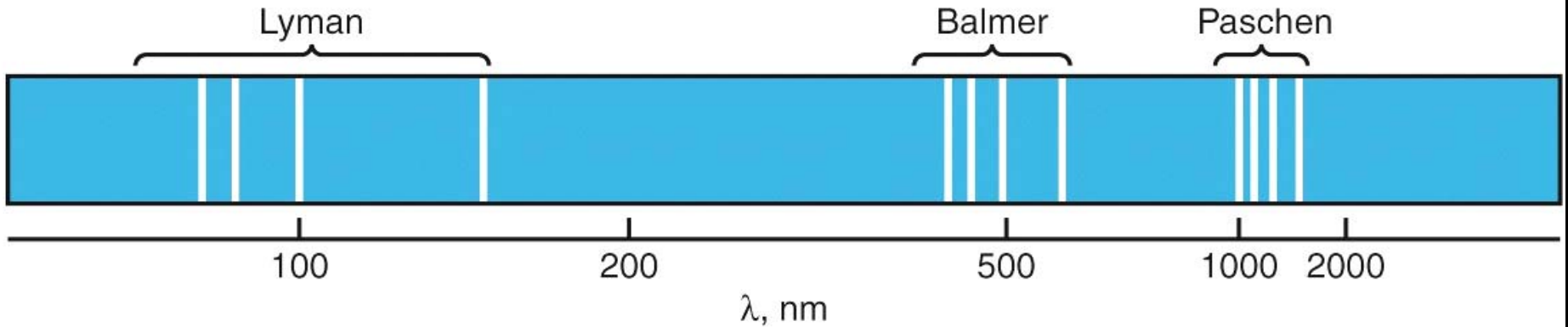

- Empirical observation (by trial & error)
- All these series can be summarized in a simple formula

$$\frac{1}{\lambda} = R \left(\frac{1}{n_f^2} - \frac{1}{n_i^2} \right), n_f > n_i, n_i = 1, 2, 3, 4..$$

Fitting to spectral line series data

$$R = 1.09737 \times 10^7 \text{ m}^{-1}$$

How does one explain this ?

The Rapidly Vanishing Atom: A Classical Disaster !

Not too hard to draw analogy with dynamics under another Central Force

Think of the Gravitational Force between two objects and their circular orbits.

Perhaps the electron rotates around the Nucleus and is bound by their electrical charge

$$F = G \frac{M_1 M_2}{r^2} \Rightarrow k \frac{Q_1 Q_2}{r^2}$$

Laws of E&M destroy this equivalent picture : Why ?

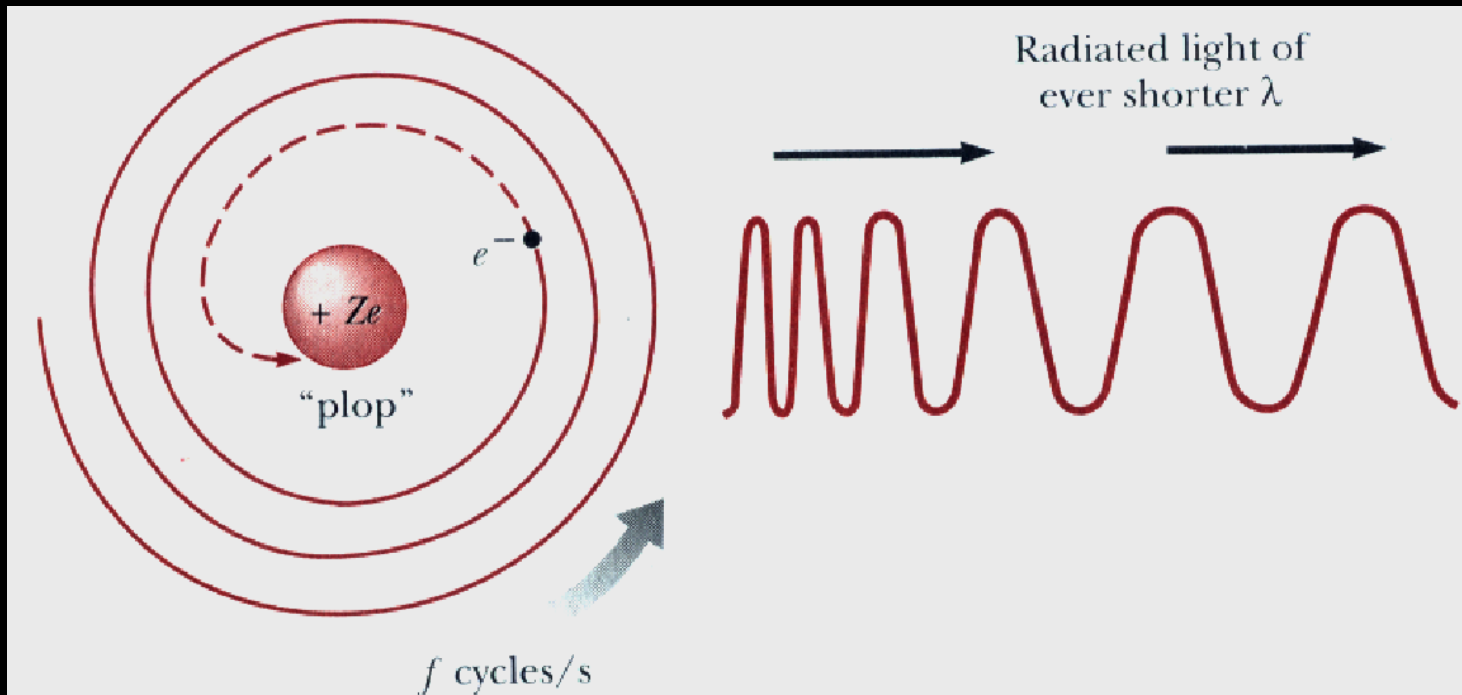

Classical Trajectory of The Orbiting Electron

Classical model of Hydrogenic Atom (Z protons) is mechanically stable but is electrically unstable !

Mechanically balanced : $F = \frac{kZe^2}{r^2} = \frac{mv^2}{r}$ (Coulomb force = Centripetal force)

But electron is always accelerating towards center of circle. Laws of classical electrodynamics predict that accelerating charge will radiate light of frequency $f = \text{freq. of periodic motion}$

$$f = \frac{v}{2\pi r} = \left(\frac{kZe^2}{rm}\right)^{\frac{1}{2}} \frac{1}{2\pi r} = \left(\frac{kZe^2}{4\pi^2 m}\right)^{\frac{1}{2}} \frac{1}{r^{\frac{3}{2}}} \sim \frac{1}{r^{\frac{3}{2}}}$$

And Total energy $E = \text{KE} + \text{U} = \frac{mv^2}{2} + \left(-\frac{kZe^2}{r}\right)$, but since $\frac{kZe^2}{2r} = \frac{mv^2}{2}$

$$\Rightarrow E = \frac{kZe^2}{2r} - \frac{kZe^2}{r} = \frac{kZe^2}{2r} \sim \left[-\frac{1}{r}\right]$$

Thus Classical physics predicts that as energy is lost to radiation, electron's orbit will become smaller and smaller while frequency of radiation will become larger and larger!

The electron will reach the Nucleus in $\sim 1\mu\text{s}$!!

In reality, this does not occur. Unless excited by external means, atoms do not radiate AT ALL!

Bohr's Bold Model of Atom: Semi Quantum/Classical

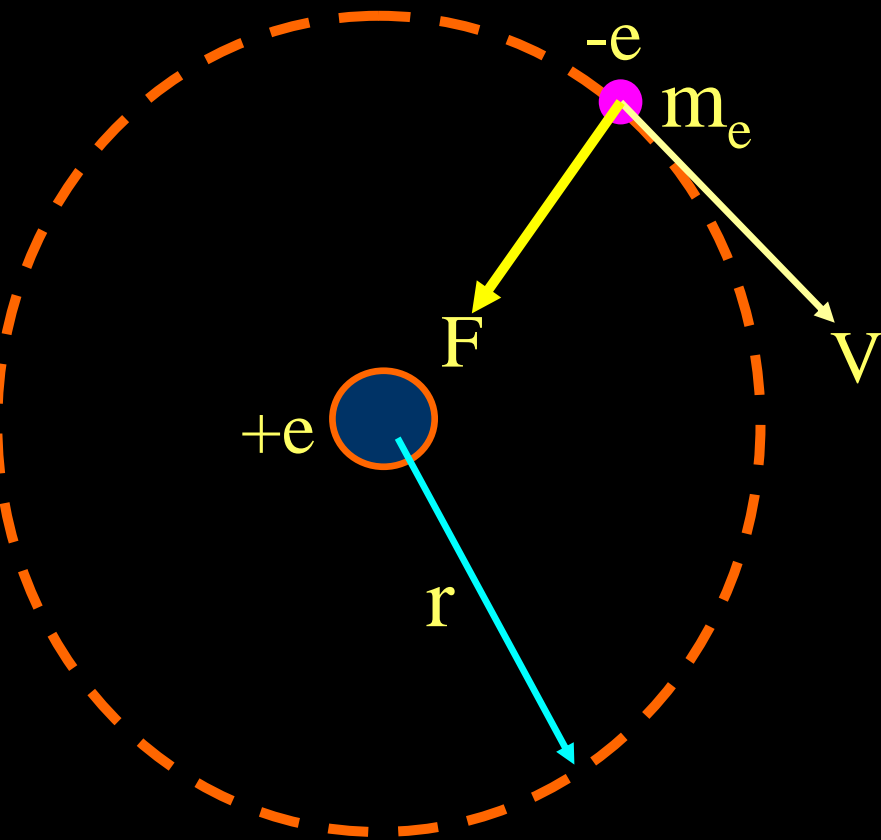

$$U(r) = -k \frac{e^2}{r}$$

$$KE = \frac{1}{2} m_e v^2$$

1. Electron in circular orbit around proton with $vel=v$
2. Only stationary orbits allowed . Electron does not radiate when in these stable (stationary) orbits
3. Orbits quantized:
 - $M_e v r = n h/2\pi$ ($n=1,2,3\dots$)
4. Radiation emitted when electron “jumps” from a stable orbit of higher energy \rightarrow stable orbit of lower energy $E_f - E_i = hf = hc/\lambda$
5. Energy change quantized
 - $f =$ frequency of radiation

Reduced Mass of 2-body system

General two body motion under a central force

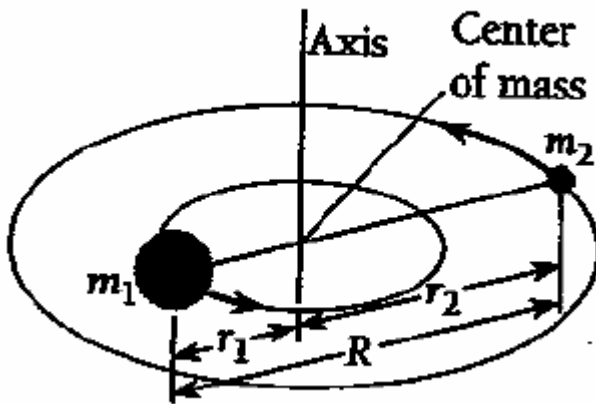

reduces to

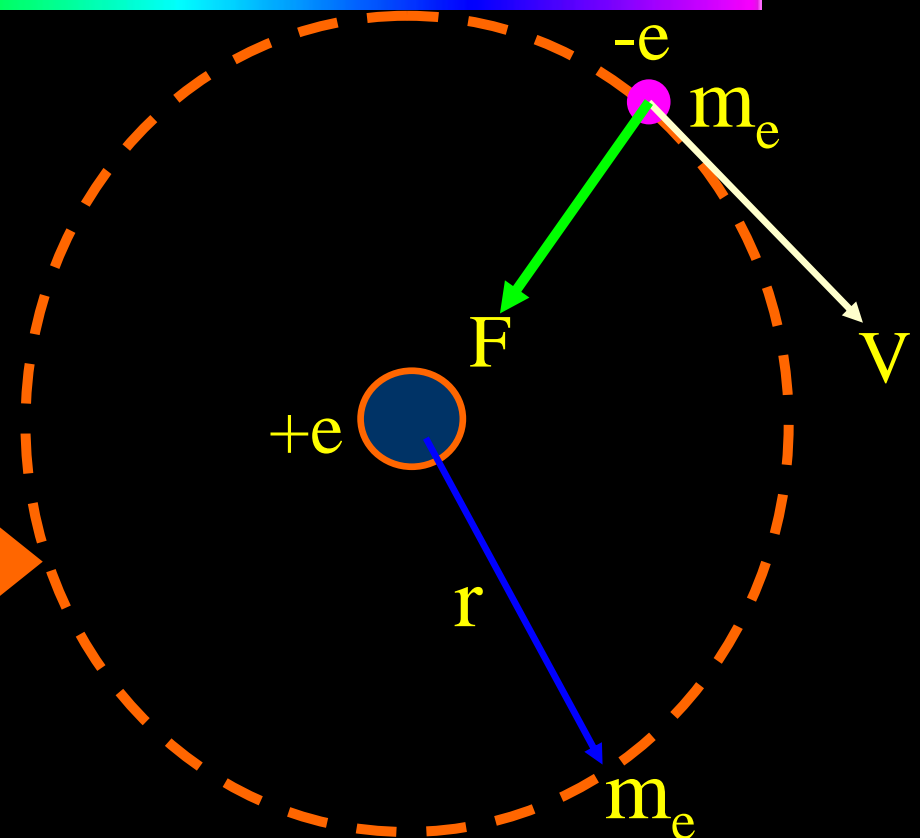

- Both Nucleus & e^- revolve around their common center of mass (CM)
- Such a system is equivalent to single particle of “reduced mass” μ that revolves around position of Nucleus at a distance of (e^- -N) separation
 - $\mu = (m_e M)/(m_e + M)$, when $M \gg m$, $\mu = m$ (Hydrogen atom)
 - Not so when calculating Muon ($m_\mu = 207 m_e$) or equal mass charges rotating around each other (similar to what you saw in gravitation)

Allowed Energy Levels & Orbit Radii in Bohr Model

$$E = KE + U = \frac{1}{2} m_e v^2 - k \frac{e^2}{r}$$

Force Equality for Stable Orbit

\Rightarrow Coulomb attraction = CP Force

$$k \frac{e^2}{r^2} = \frac{m_e v^2}{r}$$

$$\Rightarrow KE = \frac{m_e v^2}{2} = k \frac{e^2}{2r}$$

Total Energy $E = KE + U = -k \frac{e^2}{2r}$

Negative E \Rightarrow Bound system

This much energy must be added to the system to break up the bound atom

Radius of Electron Orbit :

$$mvr = n\hbar$$

$$\Rightarrow v = \frac{n\hbar}{mr}$$

substitute in KE = $\frac{1}{2} m_e v^2 = \frac{ke^2}{2r}$

$$\Rightarrow r_n = \frac{n^2 \hbar^2}{mke^2}, n = 1, 2, \dots, \infty$$

$n = 1 \Rightarrow$ Bohr Radius a_0

$$a_0 = \frac{1^2 \hbar^2}{mke^2} = 0.529 \times 10^{-10} m$$

In general $r_n = n^2 a_0; n = 1, 2, \dots, \infty$

Quantized orbits of rotation

Energy Level Diagram and Atomic Transitions

$$E_n = K + U = \frac{-ke^2}{2r}$$

since $r_n = a_0 n^2$, $n = \text{quantum number}$

$$E_n = \frac{-ke^2}{2a_0 n^2} = -\frac{13.6}{n^2} \text{ eV}, \quad n = 1, 2, 3, \dots, \infty$$

Interstate transition: $n_i \rightarrow n_f$

$$\Delta E = hf = E_i - E_f$$

$$= \frac{-ke^2}{2a_0} \left(\frac{1}{n_i^2} - \frac{1}{n_f^2} \right)$$

$$f = \frac{ke^2}{2ha_0} \left(\frac{1}{n_f^2} - \frac{1}{n_i^2} \right)$$

$$\frac{1}{\lambda} = \frac{f}{c} = \frac{ke^2}{2hca_0} \left(\frac{1}{n_f^2} - \frac{1}{n_i^2} \right)$$

$$= \mathbf{R} \left(\frac{1}{n_f^2} - \frac{1}{n_i^2} \right)$$

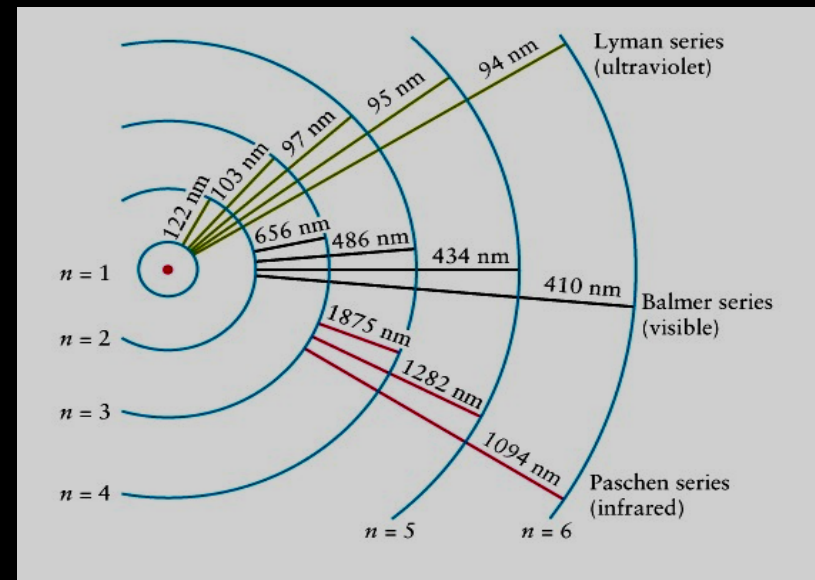
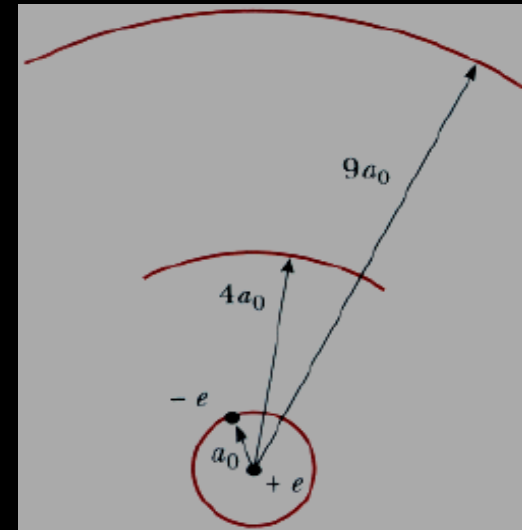

Hydrogen Spectrum: as explained by Bohr

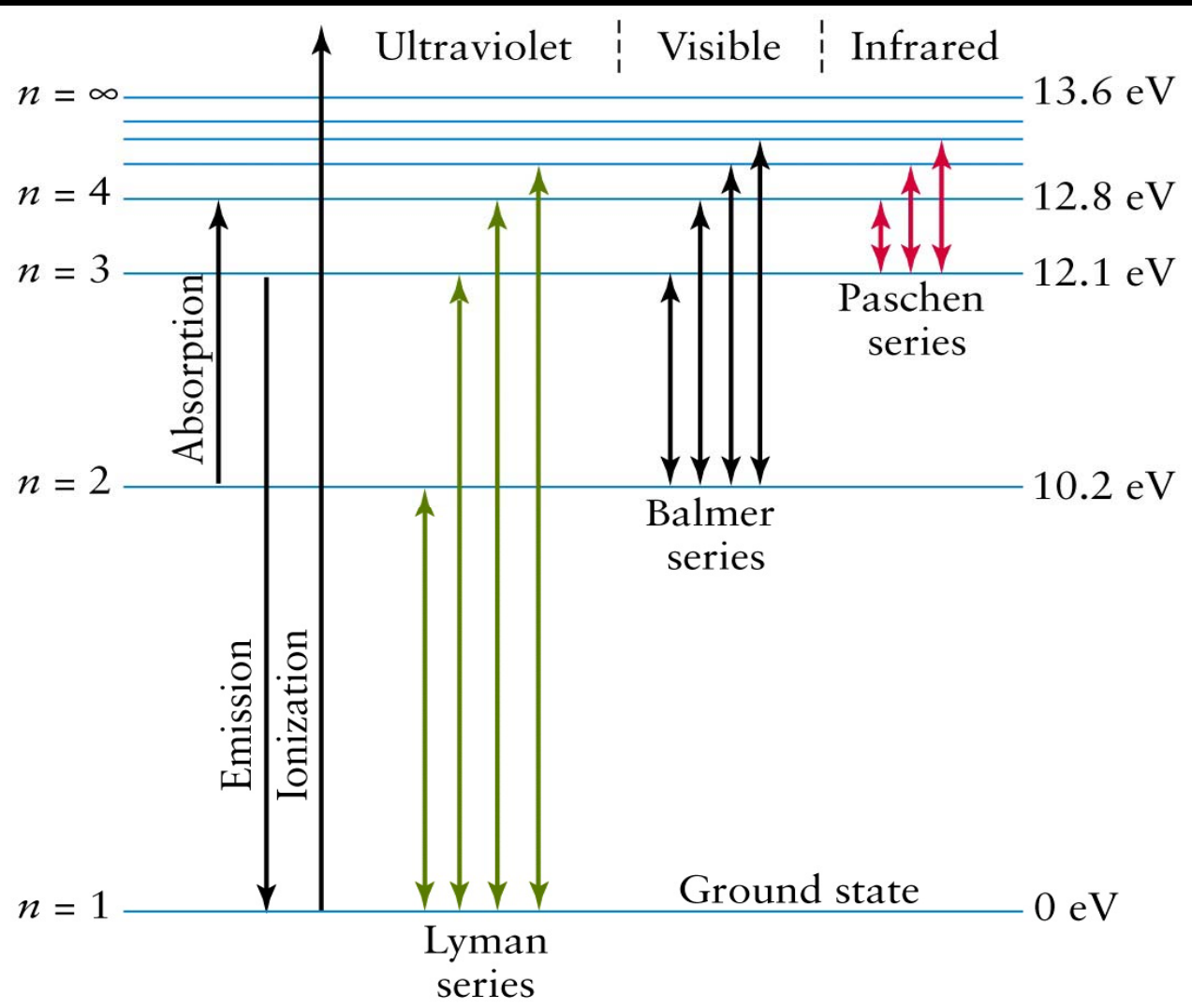

$$E_n = - \left(\frac{ke^2}{2a_0} \right) \frac{Z^2}{n^2}$$

Bohr's "R" same as Rydberg Constant **R** derived empirically from spectral series

A Look Back at the Spectral Lines With Bohr's Optic

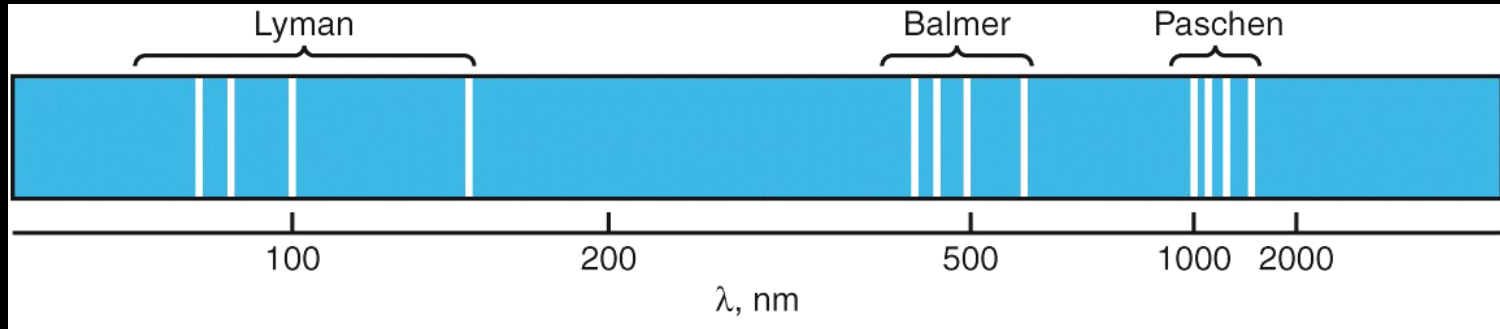

$$E_n = - \left(\frac{ke^2}{2a_0} \right) \frac{Z^2}{n^2}$$

Rydberg Constant

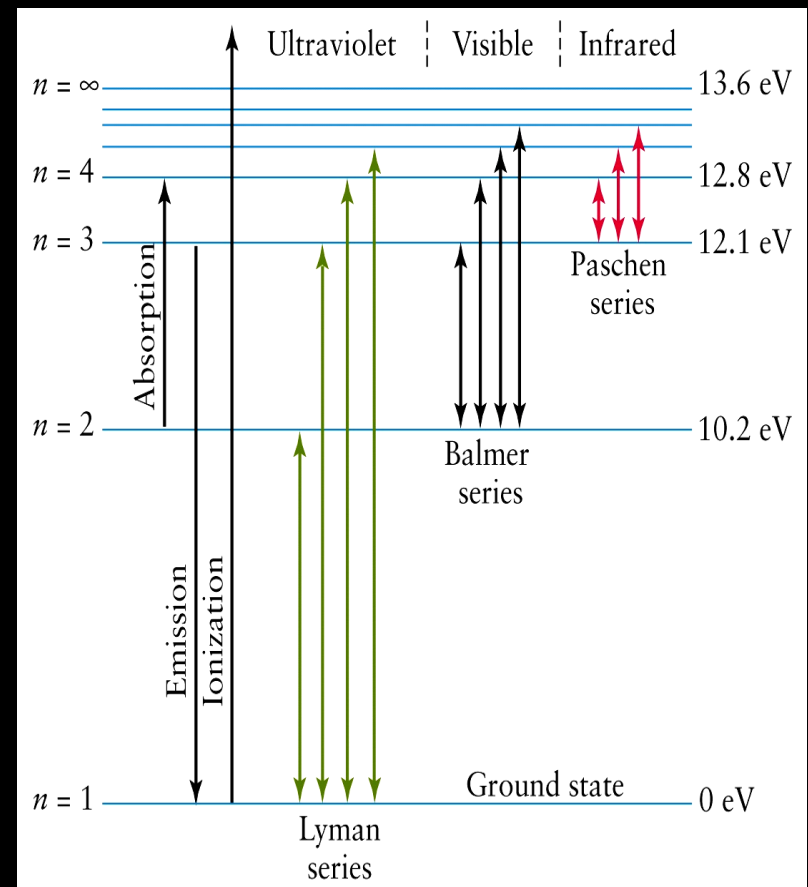

Bohr's Atom: Emission & Absorption Spectra

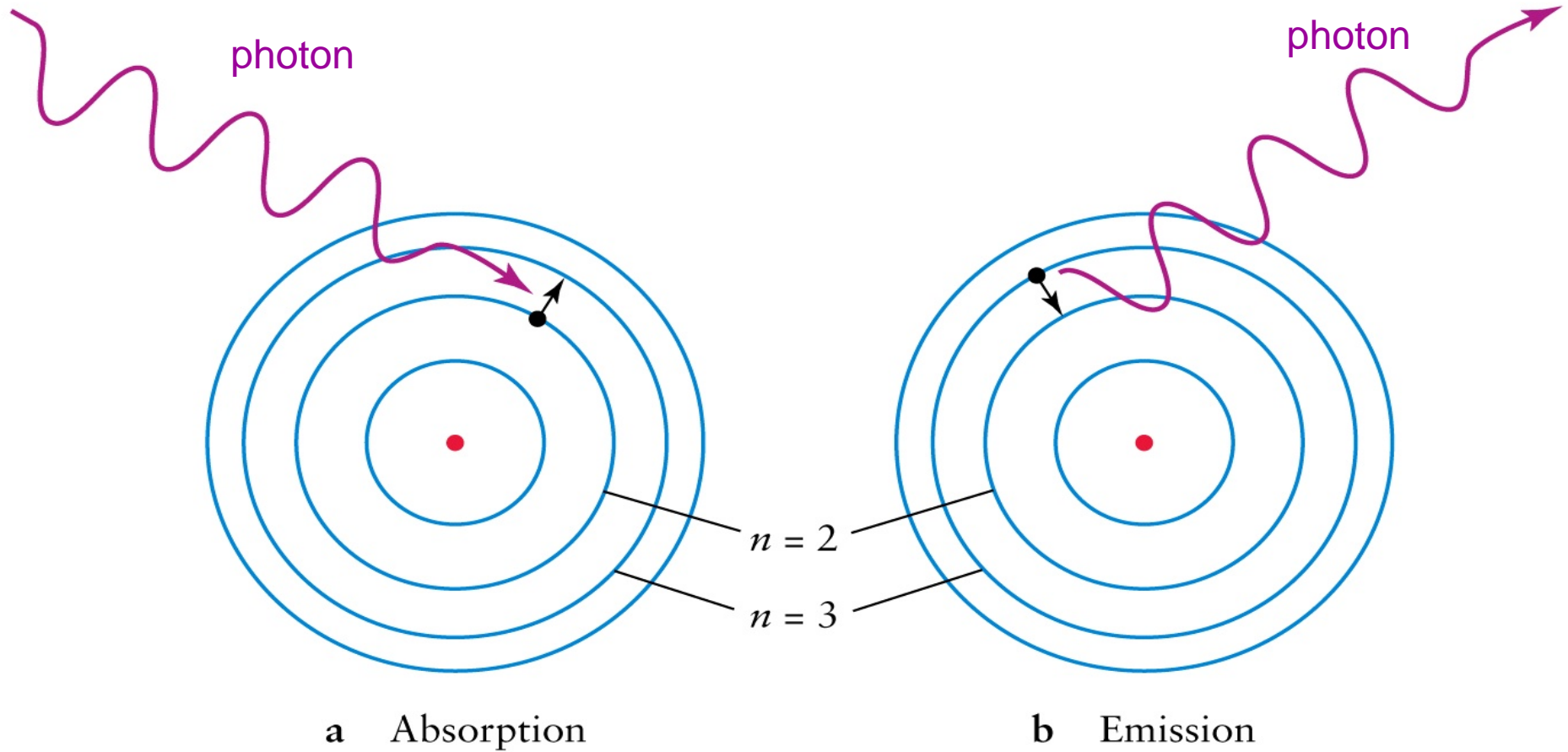

Some Notes About Bohr Like Atoms

- Ground state of Hydrogen atom ($n=1$) $E_0 = -13.6$ eV
- Method for calculating energy levels etc applies to all Hydrogen-like atoms $\rightarrow -1e$ around $+Ze$
 - Examples : He^+ , Li^{++}
- Energy levels would be different if replace electron with Muons
 - Reduced Mass
 - Necessity of Reduced Mass calculation enhanced for “positronium” like systems
- Bohr’s method can be applied in general to all systems under a central force (e.g. gravitational instead of Coulombic)

$$\text{If change } U(r) = k \frac{Q_1 Q_2}{r} \rightarrow G \frac{M_1 M_2}{r}$$

Changes every thing: E, r , f etc

"Importance of constants in your life"

Bohr's Correspondence Principle



- It now appears that there are two different worlds with different laws of physics governing them
 - The macroscopic world
 - The microscopic world
- How does one transcend from one world to the other ?
 - **Bohr's Correspondence Principle**
 - predictions of quantum theory must correspond to predictions of the classical physics in the regime of sizes where classical physics is known to hold.

when $n \rightarrow \infty$ [Quantum Physics] = [Classical Physics]

Correspondence Principle for Bohr Atom

- When $n \gg 1$, quantization should have little effect, classical and quantum calculations should give same result: Check this \rightarrow

Compare frequency of transition between level $n_i = n$ and $n_f = n - 1$

$$\begin{aligned} \text{In Bohr Model : } f &= \frac{c}{\lambda} = \frac{Z^2 m k^2 e^4}{4\pi\hbar^3} \left(\frac{1}{(n-1)^2} - \frac{1}{n^2} \right) \\ &= \frac{Z^2 m k^2 e^4}{4\pi\hbar^3} \frac{2n-1}{n^2(n-1)^2} \approx \boxed{\frac{Z^2 m k^2 e^4}{4\pi\hbar^3} \frac{1}{n^3}} \quad (\text{since when } n \gg 1, n-1 \approx n) \end{aligned}$$

$$\text{And Classically: } f_{rev} = \frac{v}{2\pi r}; \text{ using } \boxed{v = \frac{n\hbar}{mr}} \text{ and } \boxed{r = \frac{n^2\hbar^2}{mkZe^2}}$$

$$\Rightarrow f_{rev} = \frac{n\hbar / mr}{2\pi r} = \frac{n\hbar}{2\pi m r^2} = \frac{n\hbar}{2\pi m (n^2\hbar^2 / mkZe^2)^2} = \boxed{\frac{mk^2 Z^2 e^4}{2\pi\hbar^3 n^3}}$$

\Rightarrow Same!

Atomic Excitation by Electrons: Franck-Hertz Expt

Other ways of Energy exchange are also quantized ! Example:

- Transfer energy to atom by colliding electrons on it
- Accelerate electrons, collide with Hg atoms, measure energy transfer in inelastic collision (by applying retarding voltage)
- Count how many electrons get thru and arrive at P

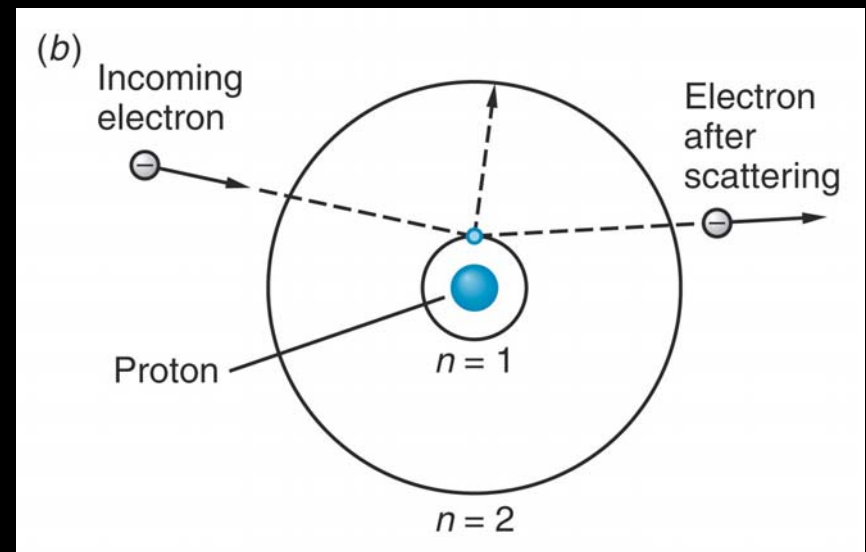
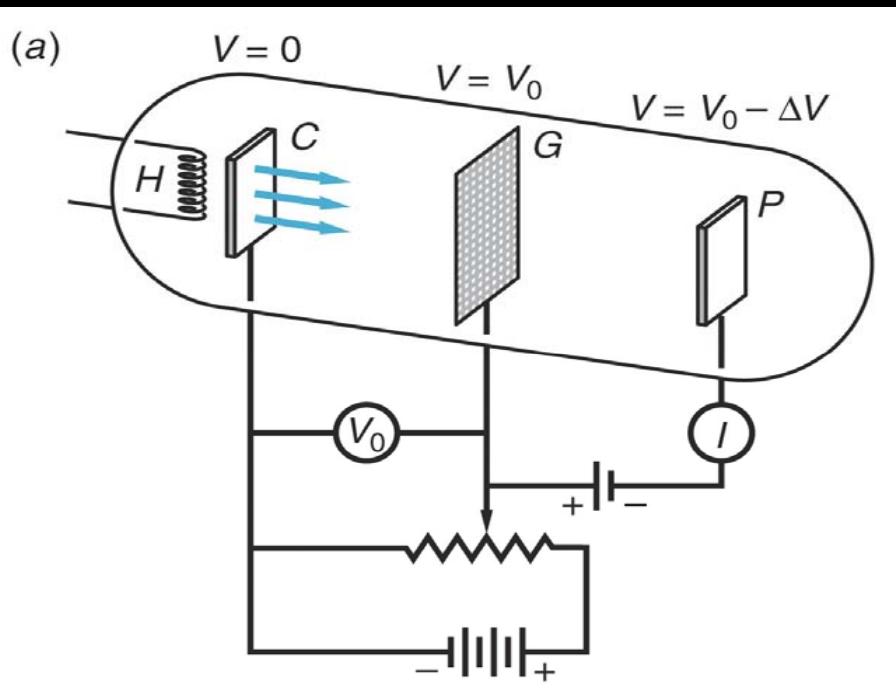

Atomic Excitation by Electrons: Franck-Hertz Expt

Plot # of electrons/time (current) overcoming the retarding potential (V)

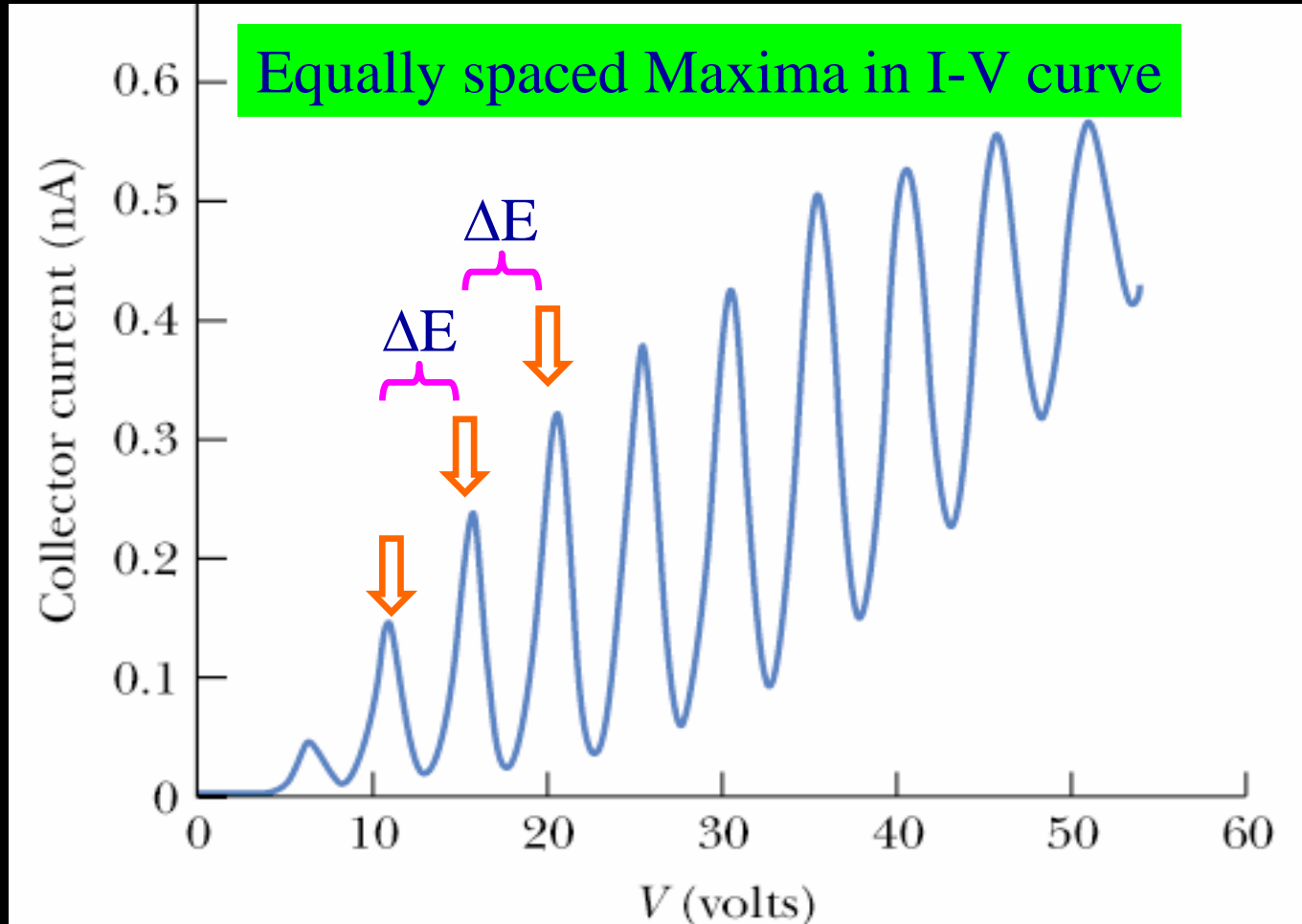

Atoms accept only discrete amount of Energy,
no matter the fashion in which energy is transferred

Bohr's Explanation of Hydrogen like atoms



- Bohr's Semi-classical theory explained some spectroscopic data → Nobel Prize : 1922
- The “hotch-potch” of classical & quantum attributes left many (such as Einstein) unconvinced
 - “appeared to me to be a miracle – and appears to me to be a miracle today One ought to be ashamed of the successes of the theory”
- Problems with Bohr's theory:
 - Failed to predict INTENSITY of spectral lines
 - Limited success in predicting spectra of Multi-electron atoms (He)
 - Failed to provide “time evolution ” of system from some initial state
 - Overemphasized Particle nature of matter-could not explain the wave-particle duality of light
 - No general scheme applicable to non-periodic motion in subatomic systems
- “Condemned” as a one trick pony ! Without fundamental insight
 - raised the question : Why was Bohr so successful?